



EXPERT TRAINING. ON SITE, ON TARGET !

FOUR INTENSIVE ON-SITE SHORT COURSES IN

# Digital Television, MPEG and Video Compression

- **MPEG-2 & Alternative Video Compression Standards and Techniques**  
3-day course
- **Digital Television (DTV): Next Generation Technology and Applications**  
3-day course
- **MPEG-4 Part 10/AVC/H.264 Advanced Video Compression**  
3-day course
- **Digital Video Basics**  
- analog & digital TV basics and signal processing  
2-day course

Instructor: Dr. Jordan Isailovic



**Training Department**

[www.jritechnology.com](http://www.jritechnology.com)

[www.advancedinteractive.com/jordan](http://www.advancedinteractive.com/jordan)

# MPEG-2 and Alternative Video Compression Standards and Techniques

on-site 3-day course (1.8 CEUs)



## Course Focus

How bad is good enough: JPEG, MPEG-1, MPEG-2, MPEG-4, MPEG-7, MPEG-21 . . .

The Moving Picture Experts Group (MPEG) was formed to establish an international standard for the coded representation of video and associated audio.

The bit rate is reduced by exploiting the psychovisual properties of the human visual system as well as statistical redundancies in the image data. The MPEG-1 algorithm utilizes motion estimation/compensation for the reduction of temporal redundancy and discrete cosine transform (DCT) for the reduction of spatial redundancy. To achieve additional compression on video data, variable length code (VLC) is also used. Another characteristic of the MPEG-1 video compression algorithm is the introduction of a bi-directional prediction method.

The MPEG-2 standard is designed for high quality use in broadcast and telecommunications applications. MPEG-2 features CCIR 601 resolution video - similar to D-1 tape (704x480 pixels/frame, NTSC; 704x576 pixels/frame, PAL) at data rates of 3 to 15 Mbits per second, and the concept of scalability. It also provides support for the interlaced format, a 16:9 video aspect ratio, and multiple video and audio channels within the same stream. In addition, MPEG-2 provides an extension ability to HDTV.

## Course Overview

This course provides a theoretical, intuitive and practical basis for the coding of images into digital form and their compression. Additionally, this course covers MPEG standards and alternative proprietary compression algorithms/standards. Compression testing, available tools and major artifacts associated with video compression are surveyed. A review of the opportunities and obstacles is given.

## Who Should Attend

The course is designed for scientists, engineers and technical managers involved in design specification, implementation, management, or utilization of video compression systems and others who wish to acquire knowledge of the video compression technology field. This course provides participants with the mathematical and conceptual background required to understand, design, implement, and evaluate video compression systems, in particular the MPEG-2 standard. Patent lawyers should also find it useful.

Attendees will benefit from the in-depth coverage of MPEG-1-2 compression standards as well as summarized current status of MPEG-4 and MPEG-7 standards and their relationship with other multimedia technologies and standards. Upon completion of this course, students will be equipped with the background that will help them understand the performance limitations of various compression solutions.

Although video compression is mathematically based, it is not assumed that attendees are familiar with higher level math: modern algebra, fractals, wavelets, etc.

## Course Objectives

- Provide background for understanding the MPEG standards
- Introduce the student to both compression standards (MPEG) and proprietary digital video formats
- Acquaint the student with their (standards/formats) capabilities and applications
- Compare the MPEG-2 algorithm with other approaches to video compression
- Consider opportunities and obstacles

## Topic Outline

### Day 1

#### Introduction

Description of Course Structure and Content  
Course Objectives  
Standards Overview

#### Analog TV: Basic Concepts

#### Digital TV: Component vs. Composite

Theoretical Base for Compression/Decompression  
Need for Data Compression  
Information Theory Concepts  
Visual Psychophysics  
Predictive Coding  
Motion Estimation  
Transform Coding  
Subband Coding  
Vector Quantization, etc.

#### Examples of Codec Designs

p\*64 Standard  
JPEG Standard

#### MPEG-1 Standard

Functional Block Diagrams  
Syntax and Semantics  
Video Compression  
Audio Compression  
System Layer  
Example: MUX for CD

### Day 2

#### MPEG-2 Standard

Video Compression  
Audio Compression  
System Layer  
Program and Transport Streams  
Comparison with MPEG-1

#### MPEG-2 Distribution

Optical Recording of the MPEG-2 Data Stream  
Satellite and Cable TV Distribution

Want to receive news about MPEG and DTV standards, and new upcoming video courses? Join our mailing list.



# MPEG-2 and Alternative Video Compression Standards and Techniques

continued from previous page

## Day 3

### Non-PEG Compression

- Wavelet Transform Coding and Compression
- Fractal Image Compression
- Autoscopy Compression

### Critical Design Issues

- DSP vs. Dedicated MPEG-1-2 IC's
- Hardware vs. Software Solutions
- Decoder Synchronization
- Format Conversion

### Limitations of Source Coding

### Major Artifacts Associated with Video Compression

- Subjective Evaluations

### Applications

- What is Available – Current Products
- Present and Future
- Opportunities and Obstacles
- Intellectual Properties
- Markets
- Testing Tools

## Instructor

**Dr. Jordan Isailovic**, scientist, JRI Technology and California State University, is author of *Videodisc and Optical Memory Technologies* and *Videodisc Systems: Theory and Applications*. He has authored numerous technical articles and holds several patents on digital information storage techniques and video signal processing. He presented the world's first public engineering course on videodisc technology (January 1982) and taught the world's first graduate courses on videodisc and optical memories (CD, CD-ROM, etc.).



His research projects include the following areas: three-dimensional optical memories, channel coding for optical recording, machine vision, image processing, testing methodology for the visually-lossless compression, etc. For the lectures, he wrote four manuscripts: *Optical Compact Systems* (including CDs and CD-ROMs), *Advanced Digital Systems Design*, *Guide to Frame Grabber Design*, and *Multimedia PC Architecture and Design*.

Dr. Isailovic's current research primarily focuses on video compression - a subject closely related to his Ph.D. thesis in which, among other things, he established the theoretical limits for TV signal compression based on 3D predictive coding. As a consultant, he has evaluated a great number of MPEG-2 encoders and decoders.

For Advanced Interactive Inc. he designed the Non-Peg Interactive TV set-top Box. He represented Packard Bell-NEC in the DVD Copy Protection Technical Working Group (CPTWG), represented Lucas Film and Technicolor in MPEG, and is still active on the MPEG committee and CPTWG. He co-chaired MPEG Digital Cinema AHG and still co-chairs SMPTE working group on DVD Authoring.

Currently, Dr. Isailovic is consulting in the field of digital cinema: evaluating/testing compression techniques, proposing system designs, participating in Standard committees on digital cinema, etc. Also, he serves as an expert witness in patent litigation: he assesses and evaluates patents and patent portfolio.

## Fee

The On-Site training course fee will guarantee space for up to 12 of attendees. (Please send us an email to : [jordan@jrtechnology.com](mailto:jordan@jrtechnology.com) or call (714)921-2286 to request an immediate quote for our training courses.)

## This Course includes:

- Three days of instruction (1.8 CEUs)
- Extensive set of notes, which cover all the visuals used in the course
- Pre-course preparatory homeworks
- Course Diploma issued by instructor

## Powerful modularized course design meets your needs...



**5 Day Full Course**

(money savings, and covering all MPEG, DTV basics in one course!)



**4 Day MPEG-2 DTV Course**

## EFFECTIVE TRAINING. ON SITE, ON TARGET !

### On-Site Course Benefits:

- **Tailored to your specific needs**
- **Enjoy confidentiality** - freely discuss your company's needs
- **May be scheduled at your convenience**
- **Significant per attendee savings** - eliminate travel and time away from the office
- **Quality course documentation**

# Digital Television (DTV): Next Generation Technology and Applications

on-site 3-day course (1.8 CEUs)



## Course Summary

There has been a quantum shift, imperceptible to the viewer, in the technology used to bring television into the home: the winning choice is digital technology. Digital TV (DTV) is the umbrella term used to describe the new digital television system adopted by the FCC in December 1996; DTV is a technology, and HDTV is just one subset of the DTV.

The objective of the course is to bring the participants gracefully through all the DTV structure, features, and theory...then give them more practical information on subjects such as decoding issues, display problems, conversion, baseband data stream handling, etc. The course will also provide an in depth and structured introduction to the technology, its uses, opportunities/possibilities, and limitations. Digital TV is not simply the numerical equivalent to traditional analog television: the issues of becoming digital are covered, as well as the relevant compression technologies.

Participants will enhance their knowledge of the principles of transmission, as well as problems and opportunities of data delivery through terrestrial, satellite and cable networks. Insight is also provided on the receiver issues and how they will handle format conversion as well as conditional access. Participants will gain a point-by-point understanding of the DTV layered architecture, DTV transmission requirements, multiplexing, MPEG switching, audio components, compatibility with today's analog TV, and more.

## Course Objectives

- Provide background for understanding the DTV standards
- Discuss enabling technologies
- Review the fundamentals of underlying modulation techniques
- Discuss specifics of ATSC, DVB-B-C Systems
- Discuss critical design issues
- Discuss technical aspects related to copy protection
- Discuss basic problems in the system integration
- Discuss opportunities and obstacles

## Who Should Attend

The course is intended for video engineers who will have to use the technology. The mathematics of compression techniques are discussed briefly, but the focus of the course is on providing a qualitative understanding of the processes involved rather than their detailed analysis. If you are looking for real world answers and direction toward solutions, this course is for you.

## Topic Outline

### Day 1

#### Introduction

- Description of Course Structure and Content
- Course Objectives
- Standards Overview

#### Standard TV - Analog: Basic Concepts

#### Standard TV - Digital: Component vs. Composite

### Day 1 (cont.)

#### Introduction to DTV/ATSC

#### Theoretical Base for Compression/Decompression

- Need for Data Compression
- Information Theory Concepts
- Visual Psychophysics
- Predictive Coding
  - Motion Estimation
  - Motion Compensation
- Transform Coding
- Subband Coding
- Vector Quantization, etc.

#### DCT xPEG (JPEG)

- Baseline Processing
- Variable Length Coding

### Day 2

#### MPEG-1 Standard

- Functional Block Diagrams
- Syntax and Semantics
- Video Compression
- Audio Compression
- System Layer

#### MPEG-2 Standard

- Video Compression
- Audio Compression
  - MPEG-1-2 Audio and AAC vs. AC-3
- System Layer
- Program and Transport Streams
- Comparison with MPEG-1

#### MPEG-2 Distribution

- Optical Recording of the MPEG-2 Data Stream
- DTV-Broadcast/ATSC

### Day 3

#### Satellite and Cable TV Distribution (DSS, DVB - Broadcast/Cable, ATSC)

#### Critical Design Issues

- DSP vs. Dedicated MPEG-1-2 IC's
- Hardware vs. Software Solutions
- Clock Recovery and Synchronization Issues
- Sampling Strategies and Structures
- CCIR-601 4:2:2 and 4:2:0; Interlaced/Noninterlaced
- VLSI Implementation
- MPEG Processing Architecture and Implementation
- Architectural choices
- Format Conversion

#### Limitations of Source Coding

#### Major Artifacts Associated with Video Compression

- Subjective Evaluations of Digitally Compressed Video

#### MPEG-4-7

#### Applications

- What is Available – Current Products
- Present and Future
- Future A/V Standards

# Digital Television (DTV): Next Generation Technology and Applications

continued from previous page

## Day 3 (Cont.)

Opportunities and Obstacles  
Patent Obligations  
Markets  
Testing Tools

## Instructor

**Dr. Jordan Isailovic**, scientist, JRI Technology and California State University. (see page 3)

## Fee

The On-Site training course fee will guarantee space for up to 12 of attendees. (Please send us an email to : [jordan@jritechnology.com](mailto:jordan@jritechnology.com) or call (714)921-2286 to request an immediate quote for our training courses.)

## This Course includes:

- Three days of instruction (1.8 CEUs)
- Extensive set of notes, which cover all the visuals used in the course
- Pre-course preparatory homeworks
- Course Diploma issued by instructor

## Powerful modularized course design meets your needs...

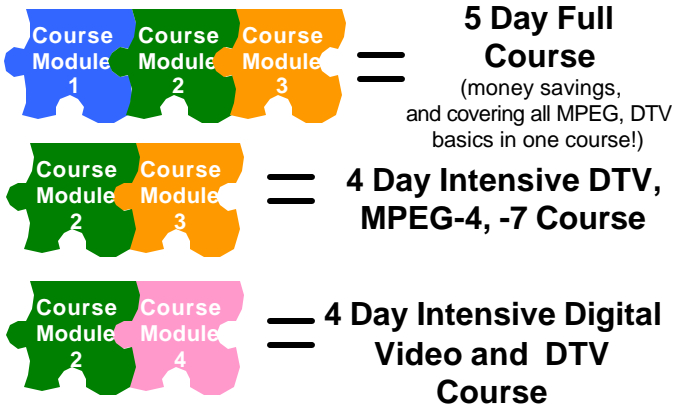

### About our clients:

Dr. Jordan Isailovic has been providing on-site and public courses to many clients including leading technology companies and key decision makers like: ADC, Ampex, ATI, AT&T, Boeing, Broadcom, Cadence, C-Cube, Cisco, Cal State Northridge, DirecTV, Diva, Extron, Echostar, GI, Hitachi, HP, Hyundai, IBM, Intel, Kodak, LSI Logic, Lucas Film, THX, Macrovision, Microsoft, Mitsubishi, Motorola, NASA, NEC, ODC, OptiBASE, OptiVision, Packard Bell, Pioneer, Polaroid, Qualcomm, Quantum, Rockwell, Sharp, S3, Samsung, Sony, TDC, Technicolor, Tektronix, Thomson, TI, Toshiba, VLSI, Zapex, Zenith, Zilog and many more...

## ATSC

Advanced Television Systems Committee. In 1978, the Federal Communications Commission (FCC) empanelled the Advisory Committee on Advanced Television Service (ACATS) as an investigatory and advisory committee to broadcast television (ATV) standard for the United States. This committee created a subcommittee, the ATSC, to explore the need for and to coordinate development of the documentation of Advanced Television Systems. In '93 the ATSC recommended that efforts be limited to a digital television system (DTV), and in '95 issued its recommendation for a Digital Television System standard, which was approved with the exclusion of compression format constants (picture resolution, frame rate, and frame sequence).

## HDTV

High Definition Television. This term refers to high-resolution TV standards. HDTV is defined as having twice the vertical and twice the horizontal resolution of conventional television, a picture aspect ratio of 16:9, a frame rate of at least 24 Hz and at least two channels of CD quality sound. HDTV is capable of generating pictures substantially brighter, sharper and of better colorimetry than 35 mm motion picture film. HDTV equipment is now commercially available and HDTV is expected to be of great importance in industrial, scientific and medical applications, as well as in entertainment.

## SDTV

Standard Definition Television. A term applied to traditional 4:3 TV in analog or digital form with a resolution of about 700 x 480 pixels. See HDTV.

## QAM

Quadrature amplitude modulation. This modulation format encodes the source data into independent in-phase and quadrature carrier components. QAM modulation is two-dimensional in the sense that the resulting signal can be represented in the complex plane.

## VSB

Vestigial sideband modulation (also called VSB-AM (amplitude modulation)). This modulation format encodes data into the amplitude of a single carrier frequency. Portions of one of the redundant AM sidebands are removed to form a vestigial sideband signal. VSB signals can be treated either as a one-dimensional AM signal or as a two-dimensional complex signal similar to the representation used for QAM.

## DTV Headlines

### FCC orders mandatory DTV tuners

By a vote of 3 to 1, the FCC has ordered electronics manufacturers to integrate digital tuners into nearly all-new consumer television receivers.

Beginning July 1, 2004, with a one-year phase-in, TV sets with screen sizes of 36 inches and larger must include digital tuners. All sets 13 inches and larger must include the tuners by July 1, 2007.

### To schedule an on-site course, contact us today.

To discuss your training needs, call our Video Training Department at (714) 921-2286 or send email to [jordan@jritechnology.com](mailto:jordan@jritechnology.com)

# Advanced Video Compression AVC/H.264

3-day course (2.5 CEUs)



## Course Focus

Advanced Video Compression, MPEG-4 AVC/H.264 is the latest international video coding standard. It is currently the most powerful and state-of-the-art standard, and was jointly developed by the Video Coding Experts Group (VCEG) of the ITU-T and the Moving Picture Experts Group (MPEG) of ISO/IEC. It uses state-of-the-art coding tools and provides enhanced coding efficiency for a wide range of applications, including video telephony, video conferencing, TV, storage (DVD and/or hard disk based, especially high-definition DVD), streaming video, digital video authoring, digital cinema, and many others. The work on a new set of extensions to this standard has been approved in the spring of 2003. These extensions, known as the Fidelity Range Extensions (FRExt, Amendment 1), provide a number of enhanced capabilities relative to the base specification.

As has been the case with past standards, its design provides the most current balance between the coding efficiency, implementation complexity, and cost - based on the state of VLSI design technology (CPU's, DSP's, ASIC's, FPGA's, etc.). In the process, a standard was created that improved coding efficiency by a factor of at least about two (on average) over MPEG-2 - the most widely used video coding standard today - while keeping the cost within an acceptable range. The Fidelity Range Extensions demonstrates even further coding efficiency against MPEG-2, potentially by as much as 3:1 for some key applications.

## Course Overview

This course provides a theoretical, intuitive and practical basis for the coding of images into digital form and their compression. Additionally, this course covers MPEG standards. Compression testing, available tools and major artifacts associated with video compression are surveyed.

Obstacles and opportunities - broadcast, streaming, downloading - will be discussed, as well as applications - DTV, PVR, HD DVD, D-cinema, videoconferencing and wireless/mobile.

## Course Objectives

- At the end of this course, students will be able to accomplish the following:
1. Understand the advantages of using digital image and video compression algorithms in various digital imaging related products.
  2. Have a clear picture of the engineering of a compression system.
  3. Compare the AVC algorithm with other approaches to video compression.
  4. Study the technical details of the MPEG and MPEG-like algorithms.
  5. Understand the essential difference between FRExt and the rest of the MPEG and/or H.26x Standards
  6. Understand requirements for: broadcast/DTV, streaming, and downloading.
  7. Make competent decisions regarding opportunities to incorporate technical advances into the product.
  8. Understand the performance limitations of various compression solutions.
  9. Learn how to get the AVC spec for free.

## Who Should Attend

The course is designed for scientists, engineers and technical managers involved in design specification, implementation, management, or utilization of video compression systems and others who wish to acquire knowledge of the video compression technology field. The material should also be of keen interest to scientists, engineers and managers working in the following roles: strategic planners, business development and marketing professionals, value-added developers and integrators, content owners/providers, etc.

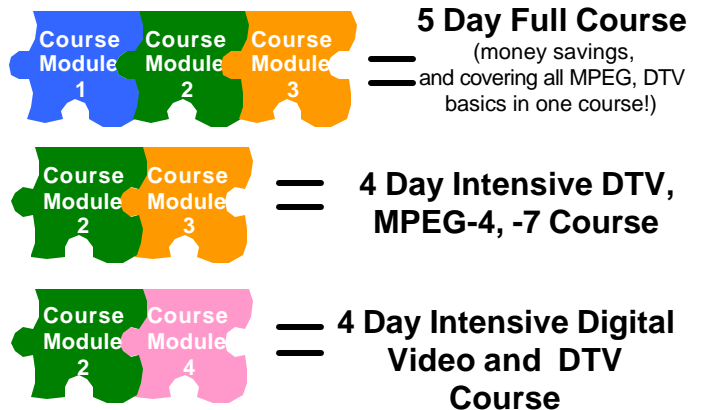

**To schedule an on-site course, contact us today.**

To discuss your training needs, call our Video Training Department at (714) 921-2286 or send email to [info@jritechnology.com](mailto:info@jritechnology.com)

# MPEG-4 Part 10/AVC/H.264

ISO/IEC 14496-10 AVC or ITU-T Rec. H.264



3-day course (2.5 CEUs)

## Topic Outline

### Day 1

#### INTRODUCTION

Description of course structure and content  
Course objectives  
Standards overview

ANALOG TV: Basic concepts

DIGITAL TV: Component vs. Composite

#### THEORETICAL BASE FOR COMPRESSION/DECOMPRESSION

Need for data compression  
Information theory concepts  
Visual Psychophysics  
Predictive coding

- Motion estimation
- Motion compensation

Transform coding

Sub-band coding

Vector quantization, etc.

xPEG Standards

JPEG STANDARD

#### MPEG-1 STANDARD

Functional block diagrams  
Syntax and semantics  
Video compression  
Audio compression  
System layer

Q/A: Major Artifacts Associated with VC

Subjective evaluations of digitally compressed video

### Day 2

#### MPEG-2 STANDARD

Video compression

Audio compression

System layer

Program and transport streams

Comparison with MPEG-1

MPEG-4 Standard Overview: Version 1, Version 2

Theoretical Base: tools, concepts, principles

Summary - MPEAG-1-2 bases

Arithmetic coding

RVLC, etc.

Theoretical Base for AVC

Advanced Video Coding (AVC) - H.264

Overview

### Day 3

Advanced Video Coding (AVC) - H.264

Compression tools

Prediction:

Prediction of Intra Macroblocks

Prediction of Inter Macroblocks

Transform and Quantization

Reconstruction filter

Interlaced Video

Flexible Macroblock Ordering (FMO)

ENTROPY CODING

(Universal) Variable Length Coding

Content-Based Adaptive Arithmetic Coding (CABAC)

Switching P and I slices

Fidelity Range Extensions

MPEG-2: System layer

Program and transport streams

NAL

MPEG-2, AVC, VC-1 comparison

Applications: Opportunities and obstacles

Markets, Patent obligations, Testing tools

### Prerequisites

Familiarity with analog and digital video would be helpful.

Although video compression is mathematically based, it is not assumed that attendees are familiar with higher level math: modern algebra, fractals, wavelets, etc.

### This Course includes:

- Three days of instruction (2.5 CEUs)
- Extensive set of notes, which cover all the visuals used in the course
- Pre-course preparatory homeworks



4 Day Complete  
MPEG Course

Also available:

Interactive course on CD: Video Compression and  
MPEG Technology Fundamentals

Copy Protection Seminar (1 or 2 days)

DVD Course (3-days)

DTV Course (3-days)

Visit us on the Web:

[www.jritechnology.com](http://www.jritechnology.com)

[www.advancedinteractive.com/jordan](http://www.advancedinteractive.com/jordan)

To schedule an on-site course, contact us today.

To discuss your training needs, call our Training Department at (714) 921-2286 or send email to [info@jritechnology.com](mailto:info@jritechnology.com)

# Digital Video Basics - analog & digital TV basics and signal processing



on-site 2-day course (1.2 CEUs)

## Course Description

Digital television is about re-invention of the television industry via digital technology, just like digital computer re-invented the computing and documenting industries. This course is about Analog and Digital TV basics and relevant signal processing. The course covers the fundamental technology that lies at the heart of compression - particularly MPEG - and high definition television (HDTV), and Digital TV in general. It is recommended as an introductory course for the MPEG-2 or DTV course.

## Course Objectives

At the completion of this course, students will have a basic understanding of how analog video is digitalized, carried, and tested. Students will gain an understanding of the processes involved in video encoding and decoding. They will be familiar with the color space and colorimetry, gamma processing, etc. Students will learn to identify common problems with digital video quality, their causes, and solutions. In addition, students will learn basic analog and digital video standards, principles standards are based on and terminology.

## Who Should Attend

The course is intended for engineers who need to understand details of digital video and review analog video in order to master video signals for developing and designing products.

## Topic Outline

### Day 1

#### ANALOG TV: BASIC CONCEPTS BLACK-and-WHITE TV SIGNAL

- Raster scan concept
- Interlacing (vs. progressive scanning)
  - Frame and Field
- Time Domain:
  - SYNC: vertical and horizontal; composite (ACTIVE) video signal
- Spectrum
- STANDARDS: RS 170, CCIR

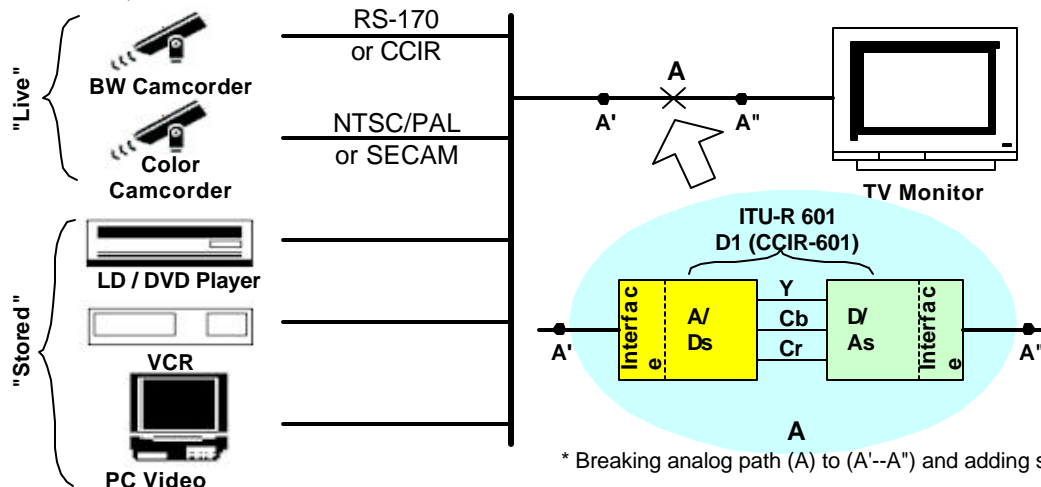

### Day 1 (cont.)

#### INTRO to COLORIMETRY COLOR TV SIGNAL

- Component: R G B; L-U-V; L-I-Q; L-Cr-Cb
- LUMA/LUMINANCE
- Composite
- Gamma - Correction
- Inerleaving
  - CHROMA/CHROMINANCE
  - COLOR SUBCARRIER (fsc)
- Standards: NTSC (RS 170A), PAL, SECAM
- Color Bar

### Day 2

#### DIGITAL TV

- Digitizing Video
- Component Digital
- Composite Digital
- Aspect Ratios
- Features & Benefits
- Signal processing

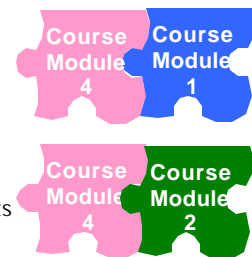

#### Introduction to ATSC

## Instructor

**Dr. Jordan Isailovic**, scientist, JRI Technology and California State University. (see page 3)

## Fee

The On-Site training course fee will guarantee space for up to 12 of attendees. (Please send us an email to : [jordan@jritechnology.com](mailto:jordan@jritechnology.com) or call (714)921-2286 to request an immediate quote for our training courses.)

## This Course includes:

- Two days of instruction (1.2 CEUs)
- Extensive set of notes, which cover all the visuals used in the course
- Pre-course preparatory homeworks
- Course Diploma issued by instructor

\* Breaking analog path (A) to (A'--A'') and adding sampling for digital video

*Time* to  
advance your professional skills  
with VDH new series of Digital TV (DTV), MPEG and  
Video Compression courses



■ Check On-Site Courses inside or Public Courses offered on the web...



- MPEG-2 & Alternative Video Compression Standards and Techniques See page 2
- Digital Television (DTV): Next Generation Technology and Applications See page 4
- MPEG-4/H.264 & MPEG-7 Multimedia Standards See page 6
- Digital Video Basics See page 7  
- analog & digital TV basics and signal processing



**Training Department**

Video Design House (VDH)  
4497 E. Pepper Creek Way  
Anaheim, CA 92807  
Email: info@jritechnology.com

**Also available:**

**Interactive course on CD: *Video Compression and MPEG Technology Fundamentals***

**Copy Protection Seminar (1 or 2 days)**

**Training Courses:**

- MPEG-2 & Alternative Video Compression Standards and Techniques
- Digital Television (DTV): Next Generation Technology and Applications

- MPEG-4 & MPEG-7 Multimedia Standards
- Digital Video Basics